

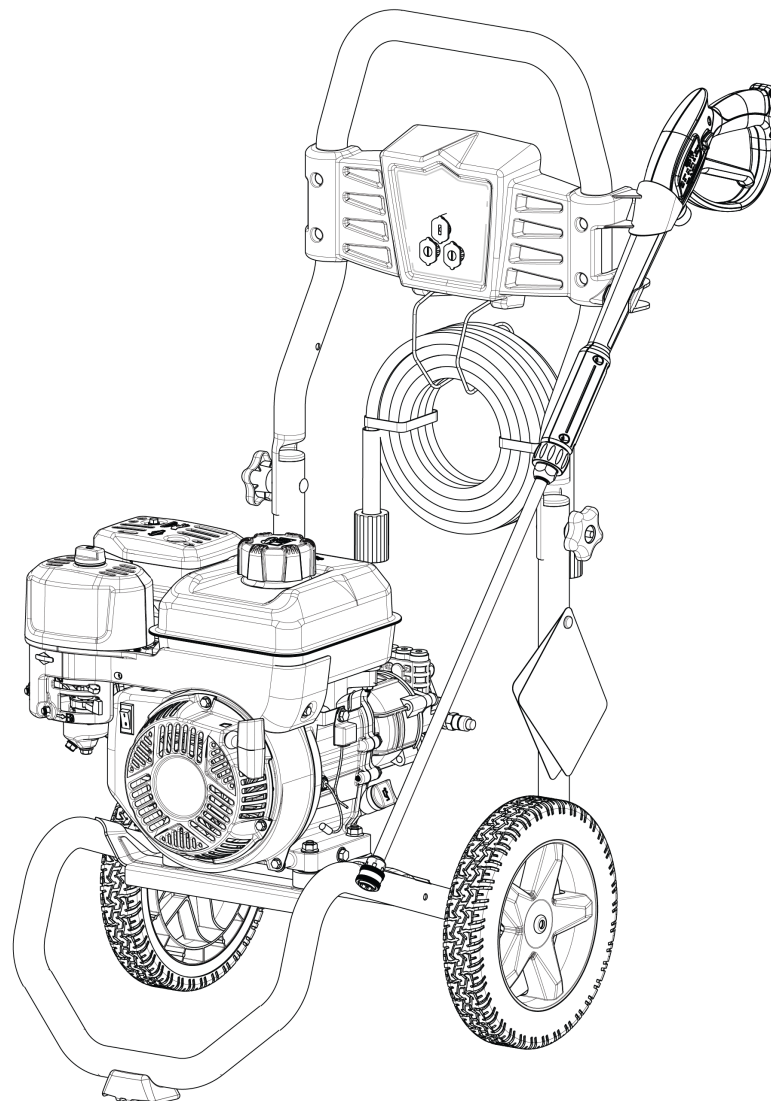

# Parts Manual

Mfg. No: 020831-00  
2,200 PSI Briggs & Stratton





---

<b>Model Components</b>	<b>Page</b>
Engine Carburetor Fuel Supply (80105039).....	4
Engine Ignition Lubrication (80105039).....	6
Engine Rewind Exhaust (80105039).....	8
Main Unit (80104393).....	10
Pump (80103166).....	12
Torque Specification Chart.....	14

Not For  
Reproduction

# Engine Carburetor Fuel Supply (80105039)

Note: Unless noted otherwise, use the standard torque specifications

Mfg. No: 020831-00

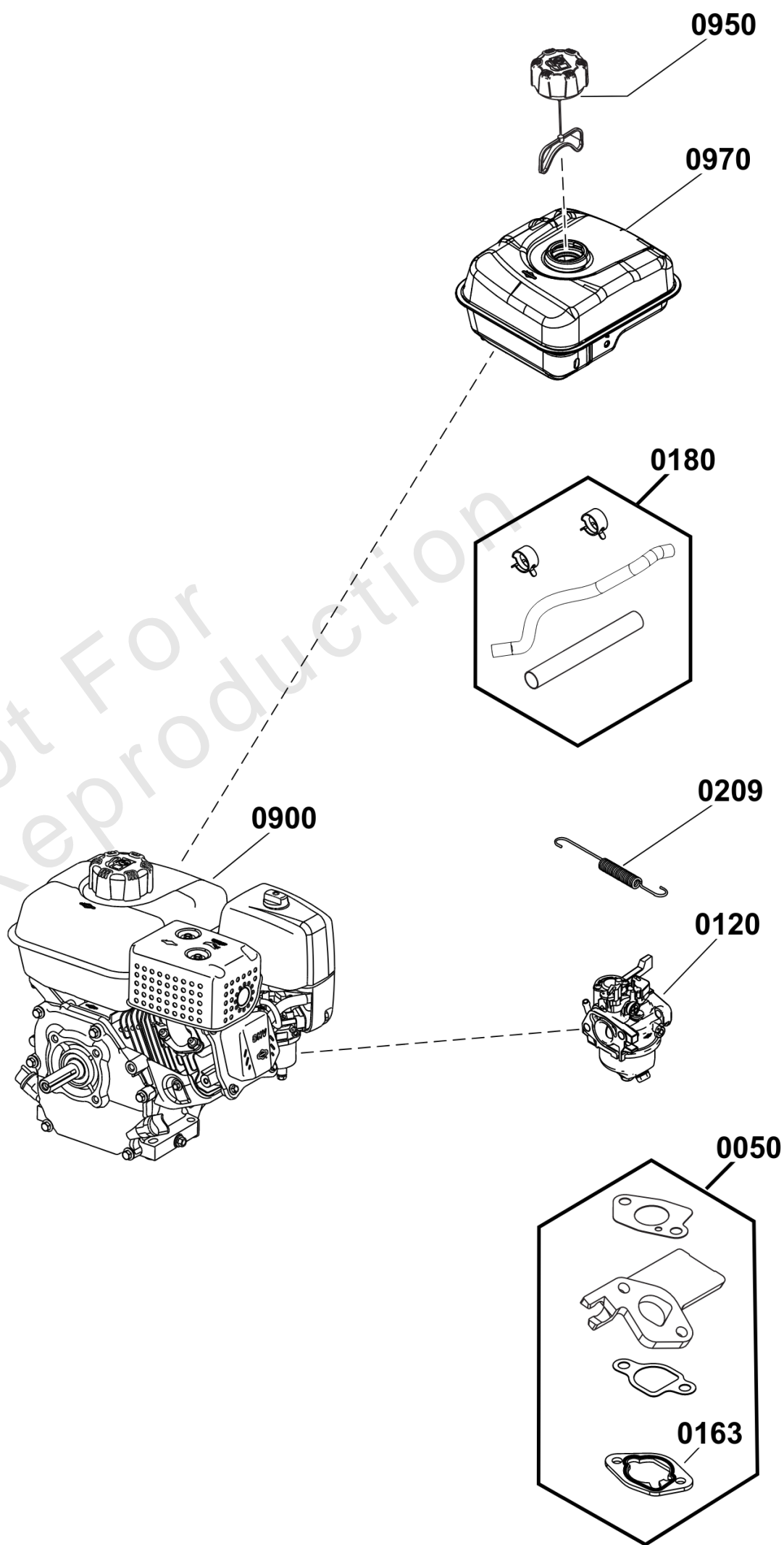

## Engine Carburetor Fuel Supply (80105039)

REF NO	PART NO	QTY	DESCRIPTION
0050	84002802	1	KIT, Carburetor Gasket -(Contains Item 0163)
0120	592236	1	CARBURETOR
0163	591013	1	GASKET, Air Cleaner
0180	84007466	1	KIT, Fuel Hose
0209	797232	1	SPRING/LINK, Governor
0900	-----	1	ENGINE, 127CC, BLACK RECOIL -(Complete Engine Not Servicable)
0950	799324	1	CAP, Fuel Tank
0970	84007468	1	TANK, Fuel -(Contains Items 0180, 0950)

Not For Reproduction

# Engine Ignition Lubrication (80105039)

Note: Unless noted otherwise, use the standard torque specifications

Mfg. No: 020831-00

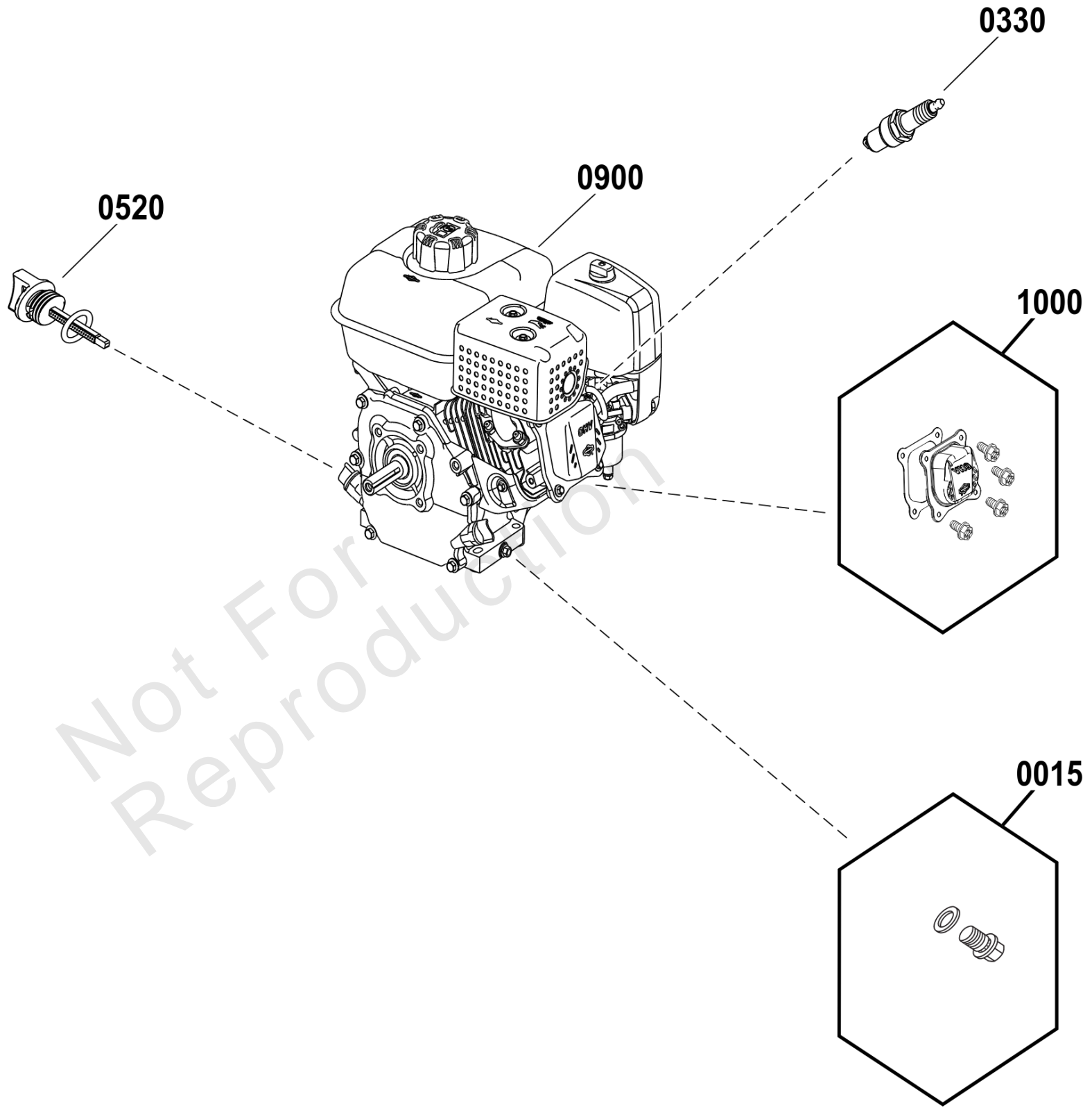

### **Engine Ignition Lubrication (80105039)**

REF NO	PART NO	QTY	DESCRIPTION
0015	797215	2	PLUG, Oil Drain -(Includes Washer)
0330	798615	1	PLUG, Spark
0520	797325	2	PLUG, Dipstick/Fill
0900	-----	1	ENGINE, 127CC, BLACK RECOIL -(Complete Engine Not Servicable)
1000	84006549	1	COVER, Rocker

Not For Reproduction

# Engine Rewind Exhaust (80105039)

Note: Unless noted otherwise, use the standard torque specifications

Mfg. No: 020831-00

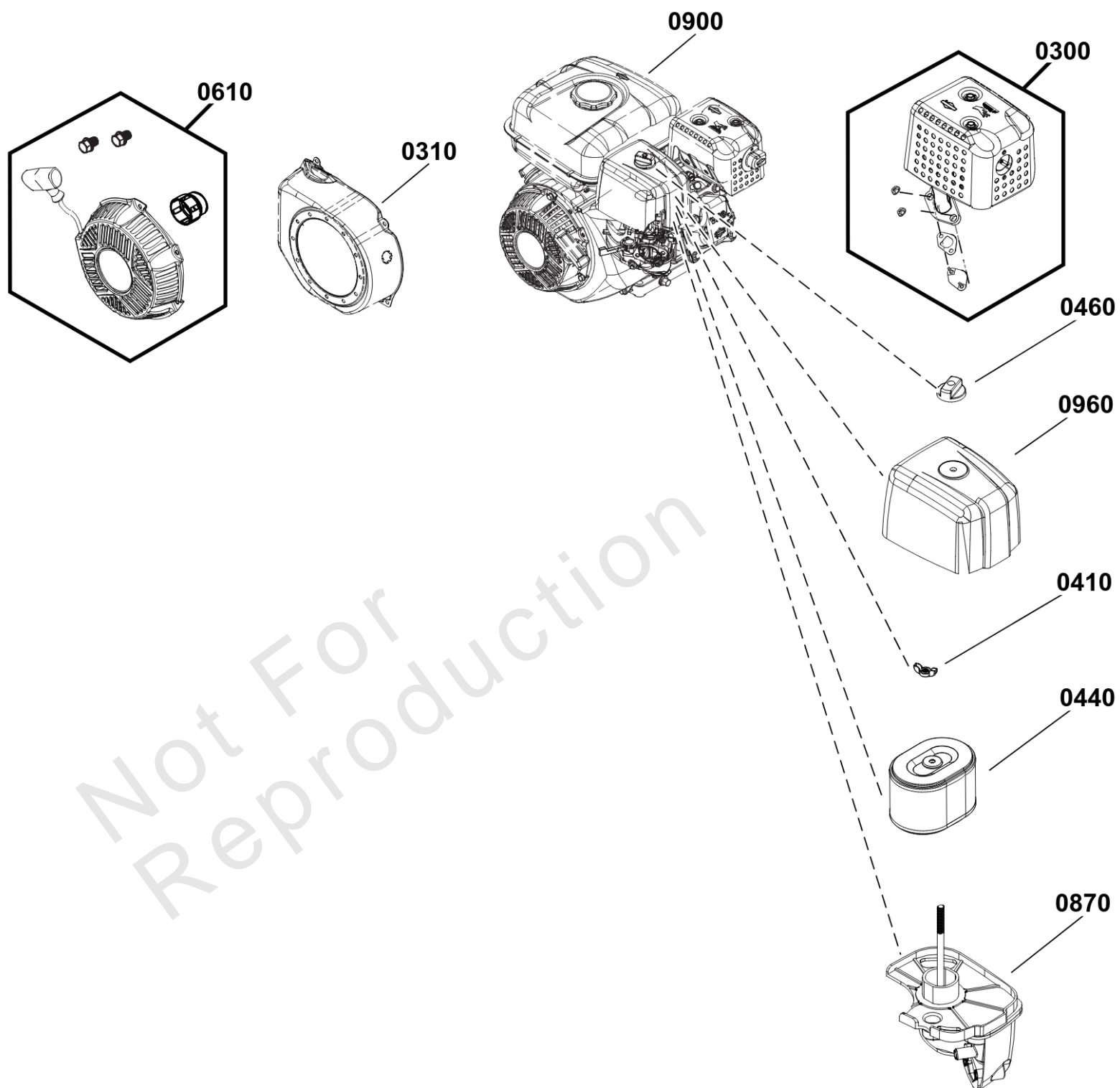



## Engine Rewind Exhaust (80105039)

REF NO	PART NO	QTY	DESCRIPTION
0300	84007462	1	MUFFLER
0310	84007463	1	HOUSING, Blower
0410	797261	1	NUT
0440	796970	1	FILTER, A/C Cartridge
0460	691985	1	KNOB, Air Cleaner Cover
0610	84007440	1	STARTER, Rewind
0870	591027	1	BASE, Air Cleaner
0900	-----	1	ENGINE, 127CC, BLACK RECOIL -(Complete Engine Not Servicable)
960	591026	1	COVER, Air Cleaner

Not For Reproduction

# Main Unit (80104393)

Note: Unless noted otherwise, use the standard torque specifications

Mfg. No: 020831-00

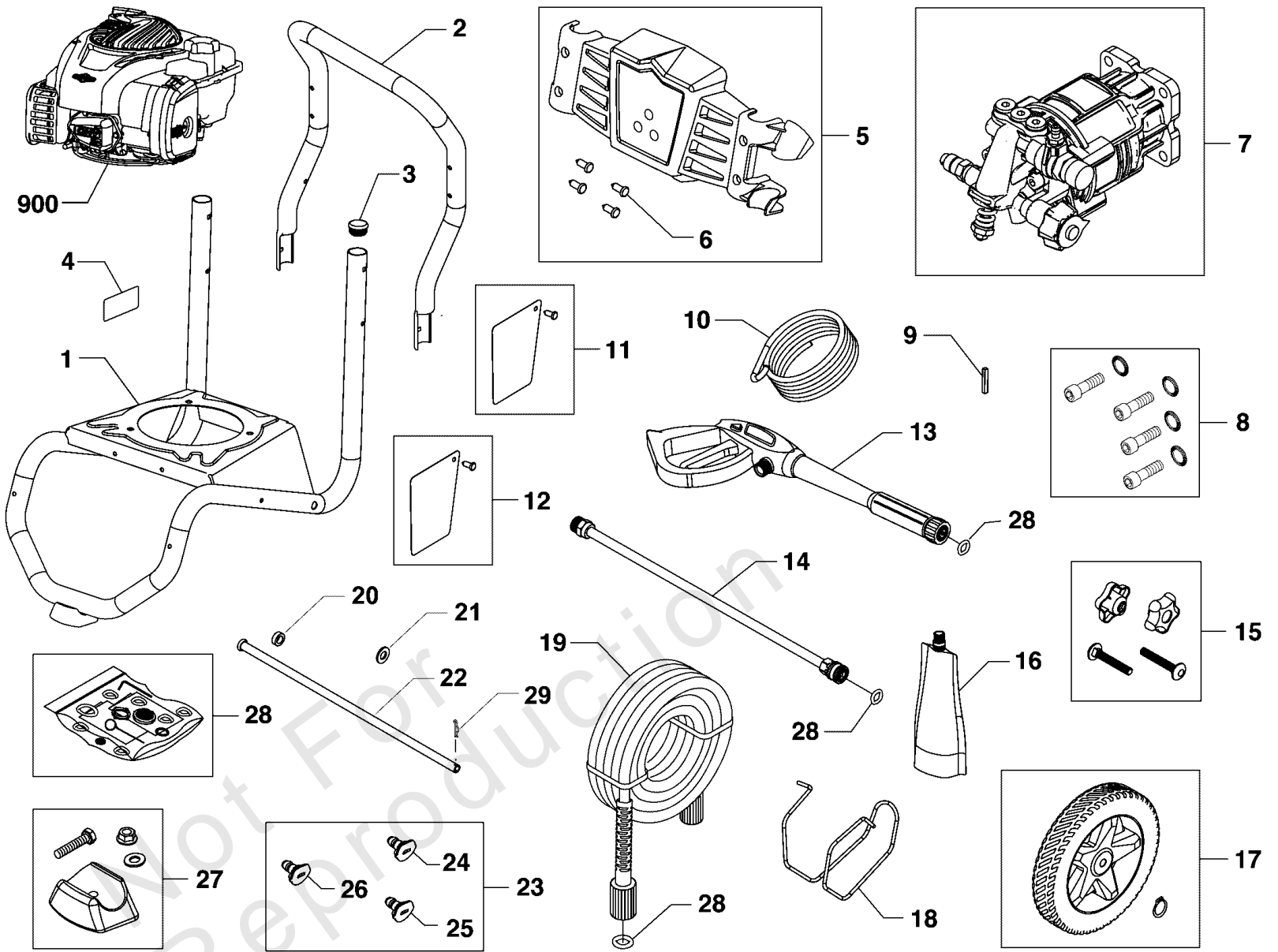

## Main Unit (80104393)

REF NO	PART NO	QTY	DESCRIPTION
1	84007076	1	BASE -(Includes Items 3 & 27)
2	84007432	1	HANDLE
3	189332GS	2	PLUG, Hole
4	705851	1	DECAL-Warning Spark
5	84007439	1	BILLBOARD -(Includes item 6)
6	B1797GS	4	CLIP
7	84007438	1	PUMP
8	192131GS	1	KIT, Hardware, Pump Mounting
9	23139DGS	1	KEY
10	705076	1	HOSE-CHEMICAL
11	84002531	1	KIT-TAG, WARNING
12	84002541	1	KIT, TAG, WARNING
13	84002234	1	GUN
14	706595	1	WAND-QC
15	84001720	1	KIT-HANDLE
16	100005	1	OIL-4 CYCLE 30W 18OZ.
17	84006367	2	KIT-WHEEL
18	84006499	1	WIREFORM
19	84006842	1	HOSE
20	84006848	1	BUSHING
21	22304GS	2	Washer, Flat 1/2
22	84007058	1	KIT, Axle -(Includes Items 20, 21 and 29)
23	319856GS	1	KIT, QC Nozzles
24	195983WGS	1	Nozzle, QC Red (Included in #10)
25	195983YGS	1	Nozzle, QC, Green
26	198841GS	1	NOZZLE, QC, Black
27	84006505	1	KIT-MOUNT, VIBRATION
28	705001	1	KIT-O-RING
29	84006849	1	CLIP-RETAINER
900	-----	1	ENGINE, 127CC, BLACK RECOIL -(Complete Engine Not Servicable, Refer to Engine Component groups)
--	6039		PUMP Saver -(Optional Accessory Not Included)
--	6059		PERFECT MIX MULTI-PURPOSE WASH -(Optional Accessory Not Included)
--	6160		Project Pro® PerfectMix Concrete, Brick, And Tile Cleaner -(Optional Accessory Not Included)

**Pump (80103166)**

Note: Unless noted otherwise, use the standard torque specifications

Mfg. No: 020831-00

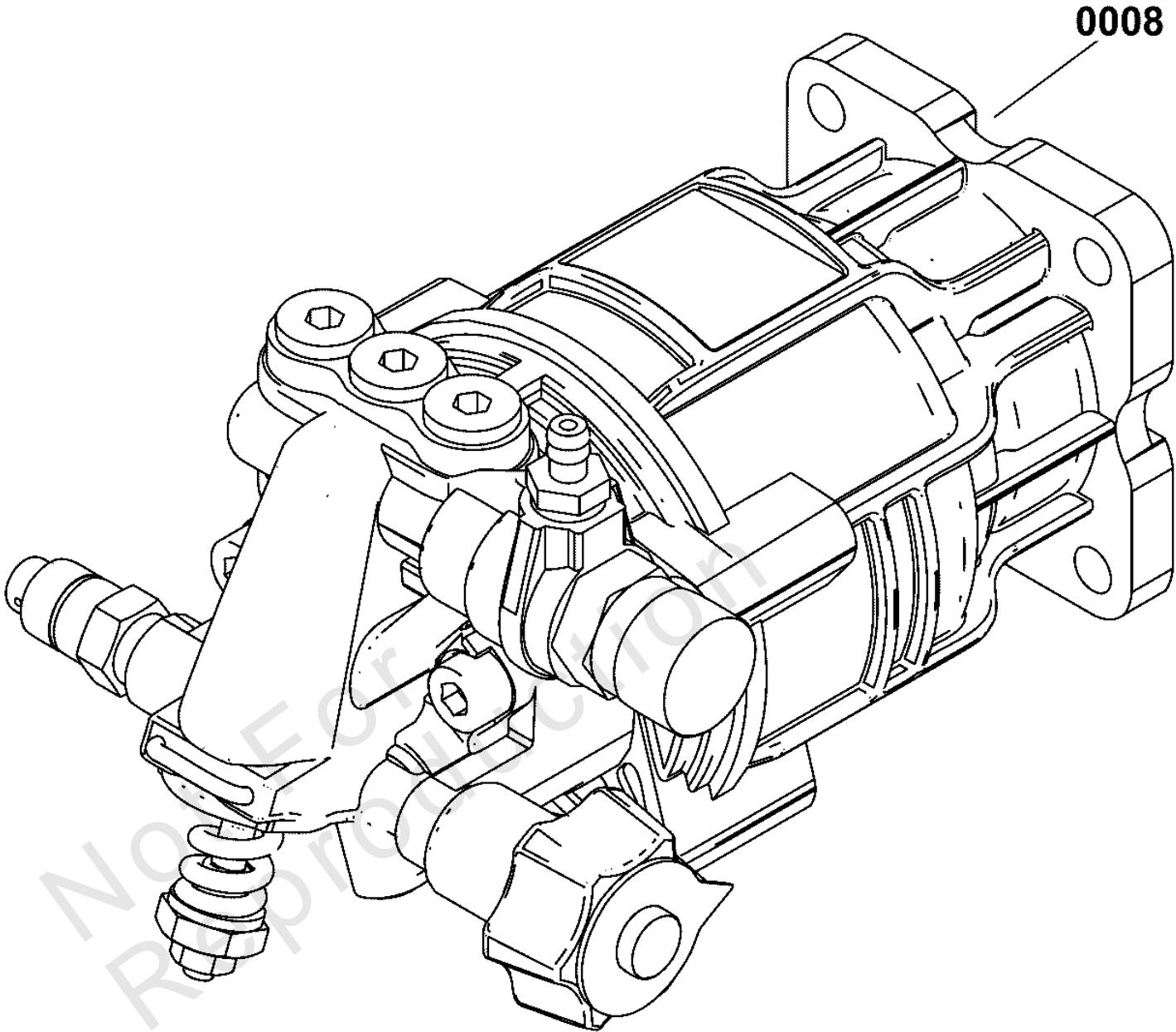

## ***Pump (80103166)***

<b>REF NO</b>	<b>PART NO</b>	<b>QTY</b>	<b>DESCRIPTION</b>
0008	84007438	1	PUMP
--	7174403	1	PUMP SAVER -(Optional Accessory - Not Included)
--	7175127	1	PUMP OIL -(Optional Accessory - Not Included)

Not For Reproduction

# Hardware Identification & Torque Specifications

Torque Specification Chart								
FOR STANDARD METRIC MACHINE HARDWARE (Tolerance ± 20%)								
Property Class	5.6		8.8		10.9		12.9	
	Class 5.6		Class 8.8		Class 10.9		Class 12.9	
Size Of Hardware	in/lbs	Nm.	in/lbs	Nm.	in/lbs	Nm.	in/lbs	Nm.
	ft/lbs		ft/lbs		ft/lbs		ft/lbs	
M3	5.88	.56	13.44	1.28	19.2	1.80	22.92	2.15
M4	13.44	1.28	30.72	2.90	43.44	4.10	52.56	4.95
M5	26.4	2.50	60.96	5.75	5.97	8.10	7.15	9.7
M6	44.64	4.3	7.3	9.9	10.3	14	12.1	16.5
M7	5.2	7.1	12.1	16.5	16.9	23	19.9	27
M8	7.7	10.5	17.7	24	25	34	29	40
M10	15	21	35	48	50	67	59	81
M12	26	36	61	83	86.2	117	103	140
M14	42	58	101	132	136	185	162	220
M16	64	88	147	200	210	285	250	340
M18	89	121	202	275	287	390	346	470
M20	126	171	290	390	405	550	486	660
M22	169	230	390	530	559	745	656	890
M24	217	295	497	375	708	960	840	1140
M27	320	435	733	995	1032	1400	1239	1680
M30	435	590	995	1350	1401	1900	1681	2280
M33	590	800	1349	1830	1902	2580	2278	3090
M36	759	1030	1740	2360	2441	3310	2935	3980
M39	988	1340	2249	3050	3163	4290	3798	5150

Torque Specification Chart						
FOR STANDARD MACHINE HARDWARE (Tolerance ± 20%)						
Hardware Grade	No Marks		SAE Grade 5		SAE Grade 8	
	SAE Grade 2		SAE Grade 5		SAE Grade 8	
Size Of Hardware	in/lbs	Nm.	in/lbs	Nm.	in/lbs	Nm.
	ft/lbs		ft/lbs		ft/lbs	
8-32	19	2.1	30	3.4	41	4.6
8-36	20	2.3	31	3.5	43	4.9
10-24	27	3.1	43	4.9	60	6.8
10-32	31	3.5	49	5.5	68	7.7
1/4-20	66	7.6	8	10.9	12	16.3
1/4-28	76	8.6	10	13.6	14	19.0
5/16-18	11	15.0	17	23.1	25	34.0
5/16-24	12	16.3	19	25.8	29	34.0
3/8-16	20	27.2	30	40.8	45	61.2
3/8-24	23	31.3	35	47.6	50	68.0
7/16-14	30	40.8	50	68.0	70	95.2
7/16-20	35	47.6	55	74.8	80	108.8
1/2-13	50	68.0	75	102.0	110	149.6
1/2-20	55	74.8	90	122.4	120	163.2
9/16-12	65	88.4	110	149.6	150	204.0
9/16-18	75	102.0	120	163.2	170	231.2
5/8-11	90	122.4	150	204.0	220	299.2
5/8-18	100	136	180	244.8	240	326.4
3/4-10	160	217.6	260	353.6	386	525.0
3/4-16	180	244.8	300	408.0	420	571.2
7/8-9	140	190.4	400	544.0	600	816.0
7/8-14	155	210.8	440	598.4	660	897.6
1-8	220	299.2	580	788.8	900	1,244.0
1-12	240	326.4	640	870.4	1,000	1,360.0

The guides and ruler furnished below are designed to help you select the appropriate hardware.

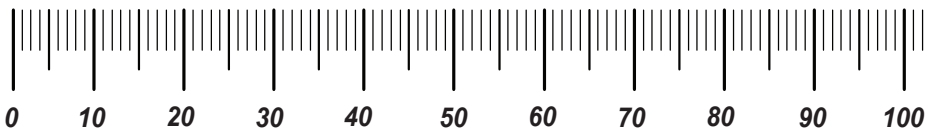

Nut, M8

Thread Diameter (mm)

Inside Diameter (in)      Threads per inch

Nut, 1/2-16

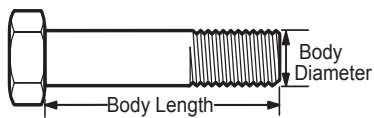

Screw, M8- 1.25 x 25

Thread Diameter (mm)      Distance between threads (mm)      Body Length (mm)

Body Diameter      Threads per inch      Body Length (in)

Screw, 1/2- 16 x 2

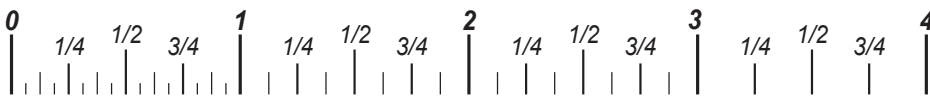

## Standard Hardware Sizing

When a washer or nut is identified as 1/2" (M8), this is the *Nominal size*, meaning the *inside diameter* is 1/2 inch (8mm metric thread diameter); if a second number is present it represents the *threads per inch* (distance between threads).

When bolt or capscrew is identified as 1/2 - 16 x 2" (M8 - 1.25 x 50), this means the *Nominal size*, or body diameter is 1/2 inch (8mm metric thread diameter), the second number, 16, represents the *threads per inch*, (*distance between threads*). The final number is the body length of the bolt or screw, 2 inches (50mm).

## NOTES

- These torque values are to be used for all hardware excluding: locknuts, self-tapping screws, thread forming screws, sheet metal screws and socket head setscrews.
- Recommended seating torque values for locknuts:
  - for prevailing torque locknuts - use 65% of grade 5 torques.
  - for flange whizlock nuts and screws - use 135% of grade 5 torques.
- Unless otherwise noted on assembly drawings, all torque values must meet this specification.

## Common Hardware Types

Hex Head Capscrew

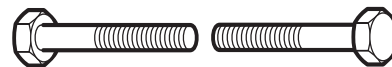

Washer



Carriage Bolt



Hex Nut

## Wrench & Fastener Size Guide

1/4" Bolt or Nut Wrench—7/16"	5/16" Bolt or Nut Wrench—1/2"	3/8" Bolt or Nut Wrench—9/16"	7/16" Bolt or Nut Wrench (Bolt)—5/8" Wrench (Nut)—11/16"	1/2" Bolt or Nut Wrench—3/4"
M6 Bolt or Nut Wrench—10mm	M8 Bolt or Nut Wrench—13mm	M10 Bolt or Nut Wrench—17mm	M12 Bolt or Nut Wrench—19mm	M14 Bolt or Nut Wrench—22mm

